



Technologia, Innowacje, Mobilność



Prezentacja wyników – I kwartał 2017 r.

Warszawa, 23 maja 2017 r.

tim.pl





TIM.pl statystyki – I kw. 2017 r./I kw. 2016 r.

593 723 / 457 639 UU (+30%)

81% / 78% mężczyźni

1 910 229 / 1 466 208 sesji (+30%)

2 143 115 / 1 877 278 unikalnych haseł w wyszukiwarce (+14%)

7 min 10 s / 8 min 40 s średni czas sesji (-1 min 30 s)

37% / 35% 25-34 lata

10% / 12% 55-64 lata

27% / 28% 35-44 lata





Produkcja budowlano-montażowa

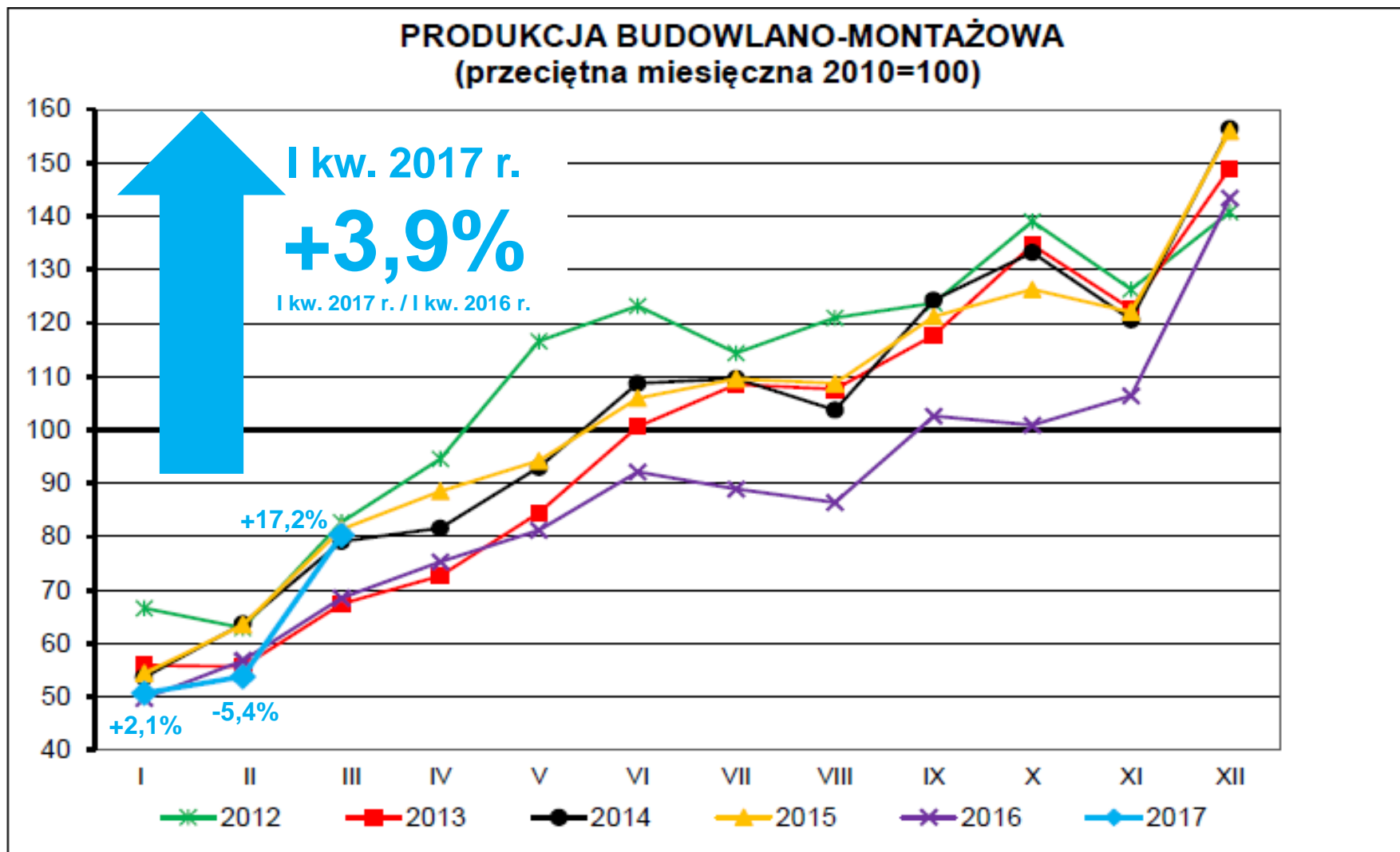



TIM vs rynek

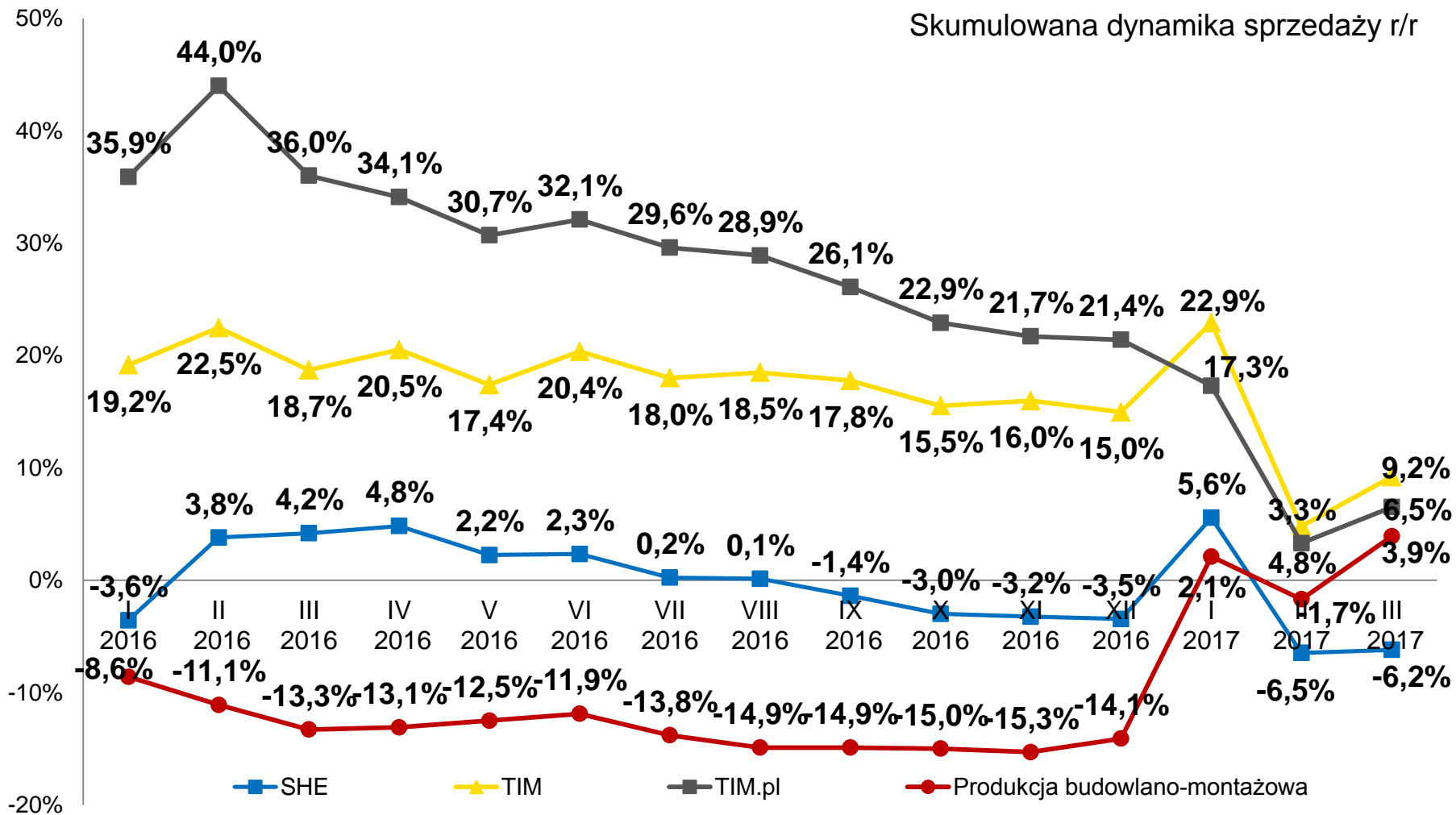



Kluczowe KPI

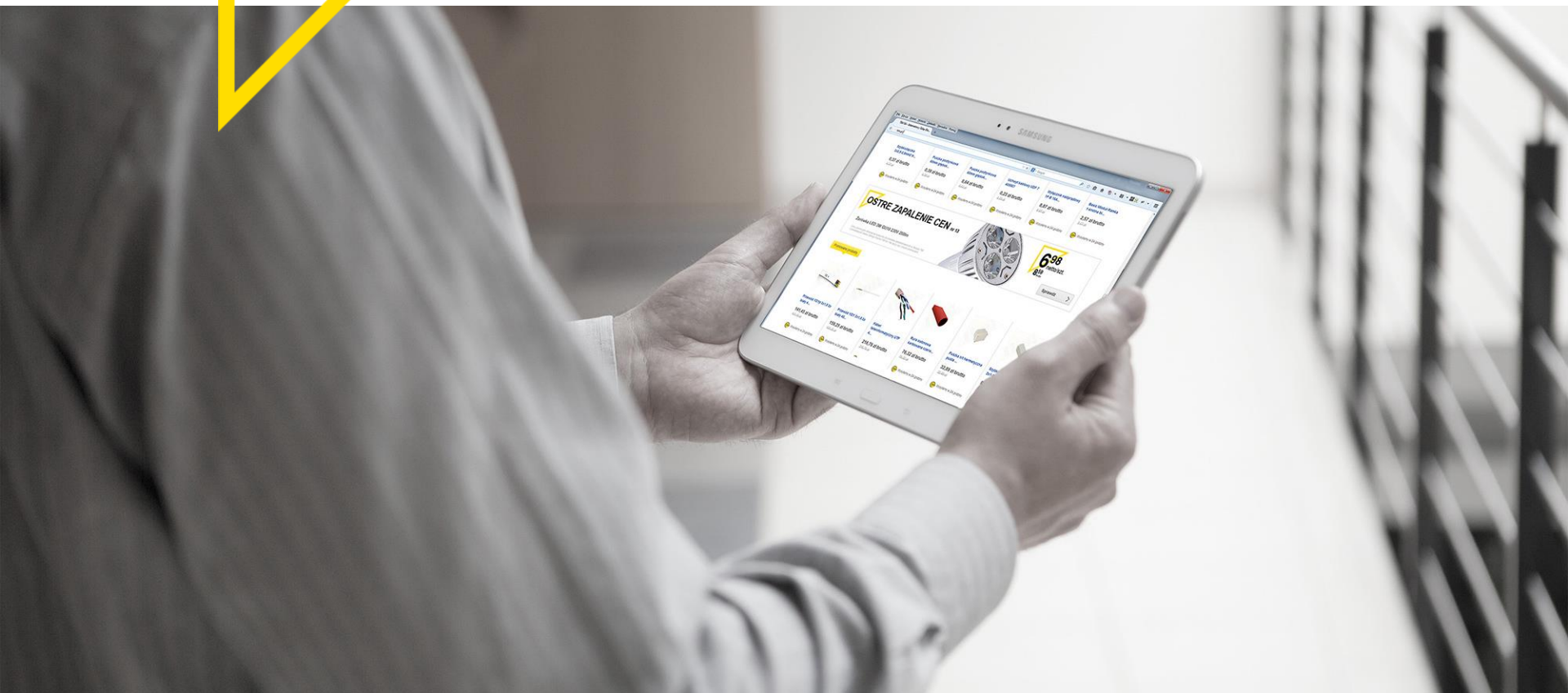



Przychody ze sprzedaży – TIM SA

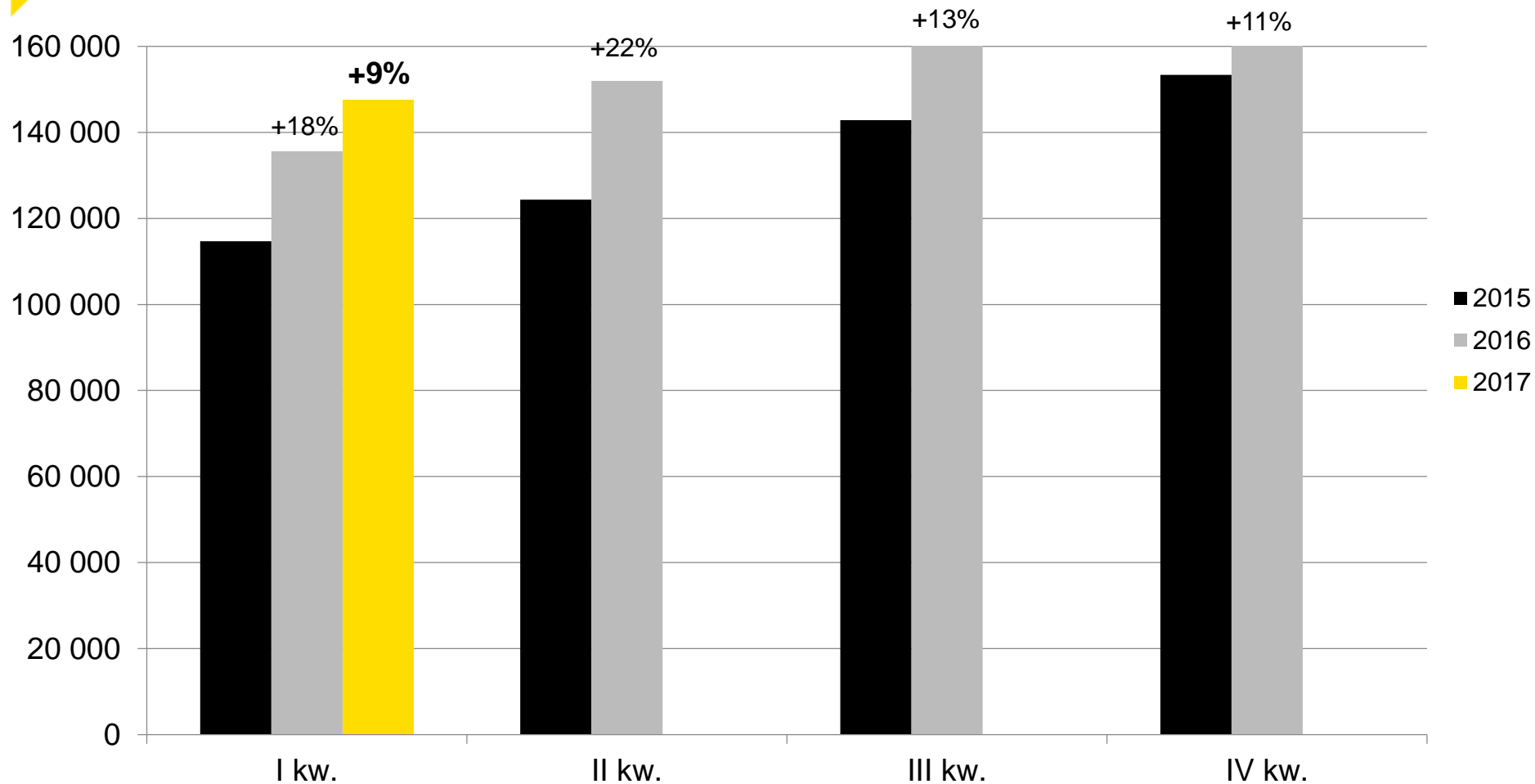

wartości w tys. PLN

	2016	2017	zmiana
I kw.	135 614	147 646	+8,9%

tim.pl





Sprzedaż według kanałów

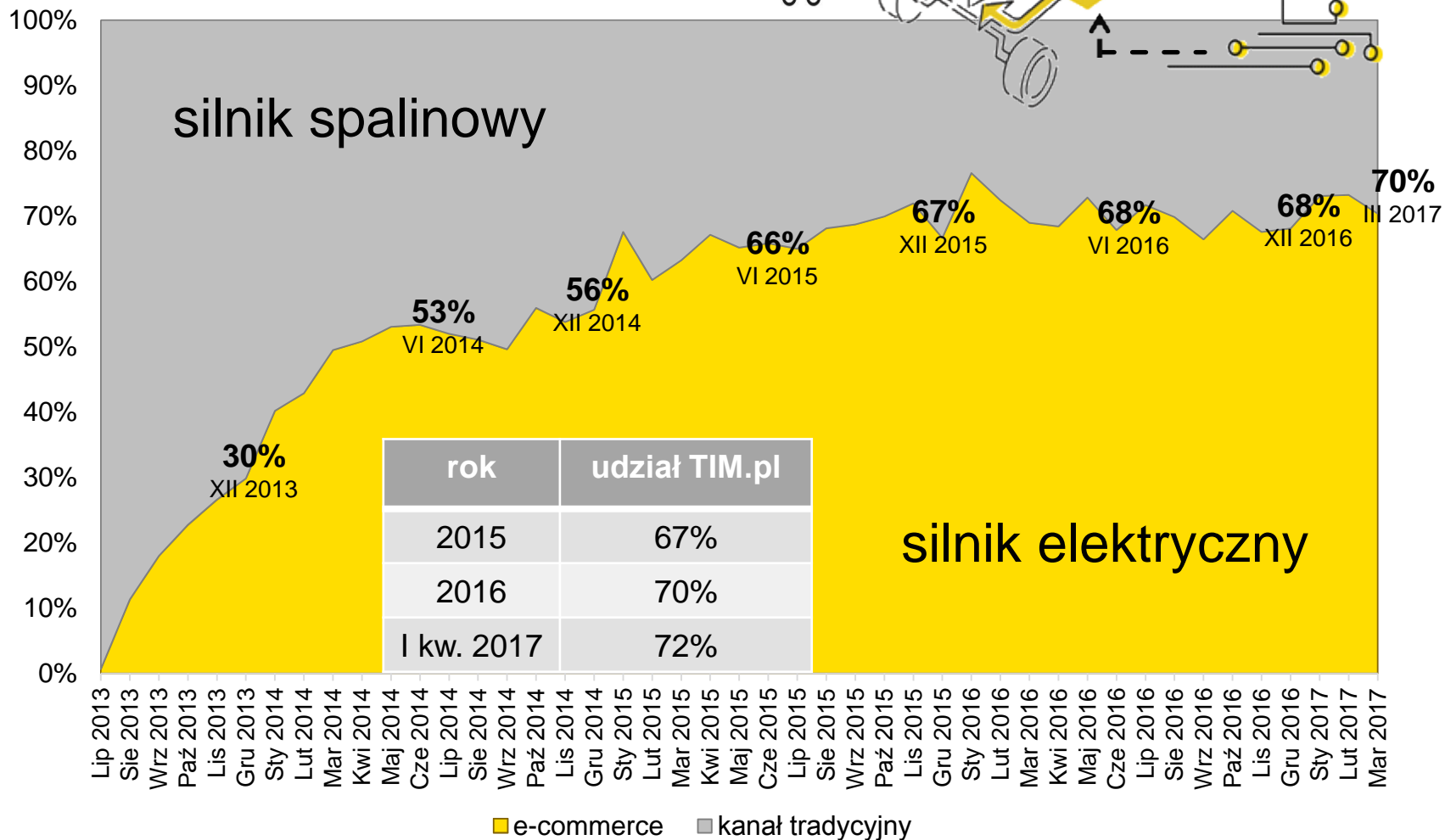
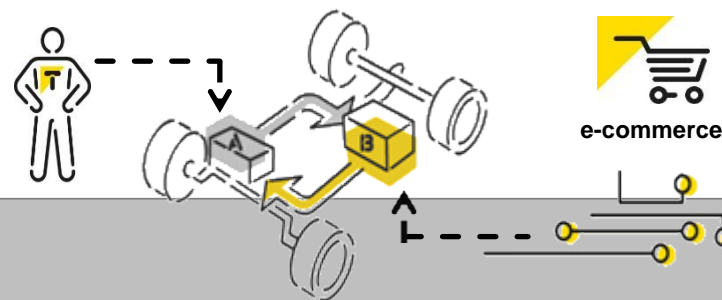



Standaryzacja sprzedaży

I kw. 2016 r. przychody: **135,6 mln zł**

dynamika **109%**

I kw. 2017 r. przychody: **147,6 mln zł**

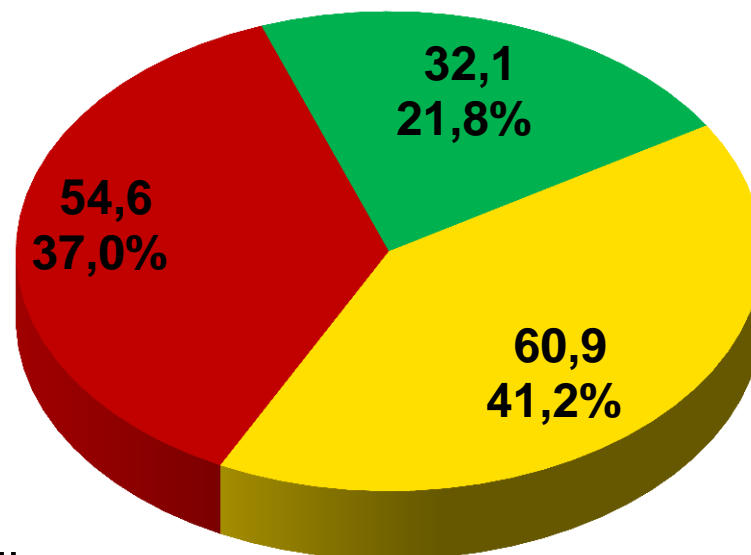
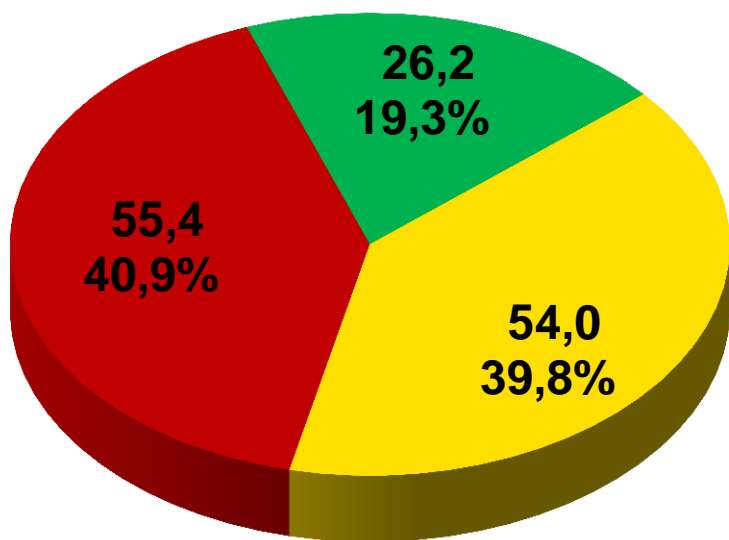

dynamika



123%

produkty
wysokomarżowe
marża > 20%



113%

produkty
średniomarżowe
marża 10% - 20%



99%

produkty
niskomarżowe
marża < 10%





Sprzedaż według segmentów rynku - I kw. 2017 vs I kw. 2016 r.

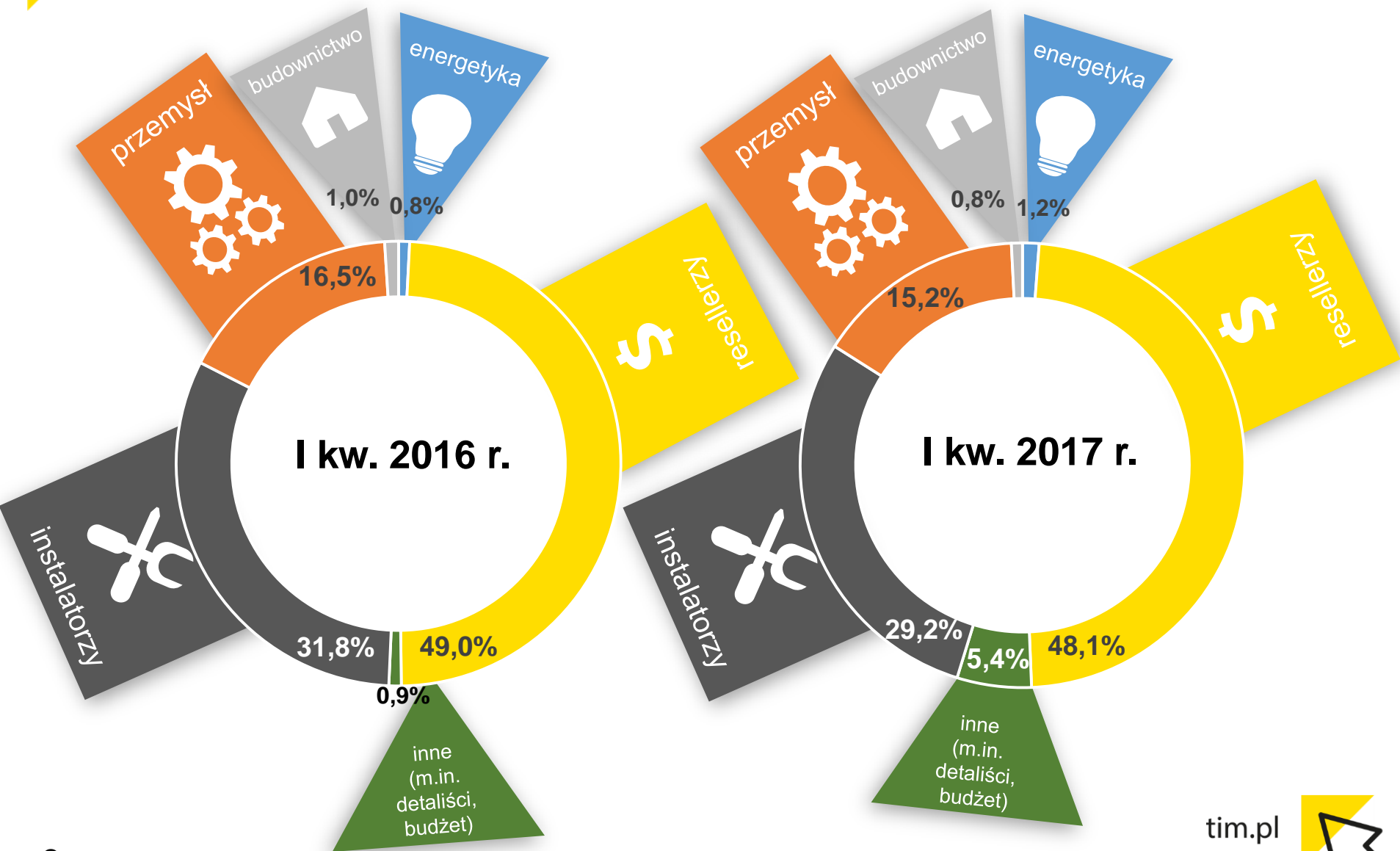



Najszerza oferta produktowa w Polsce

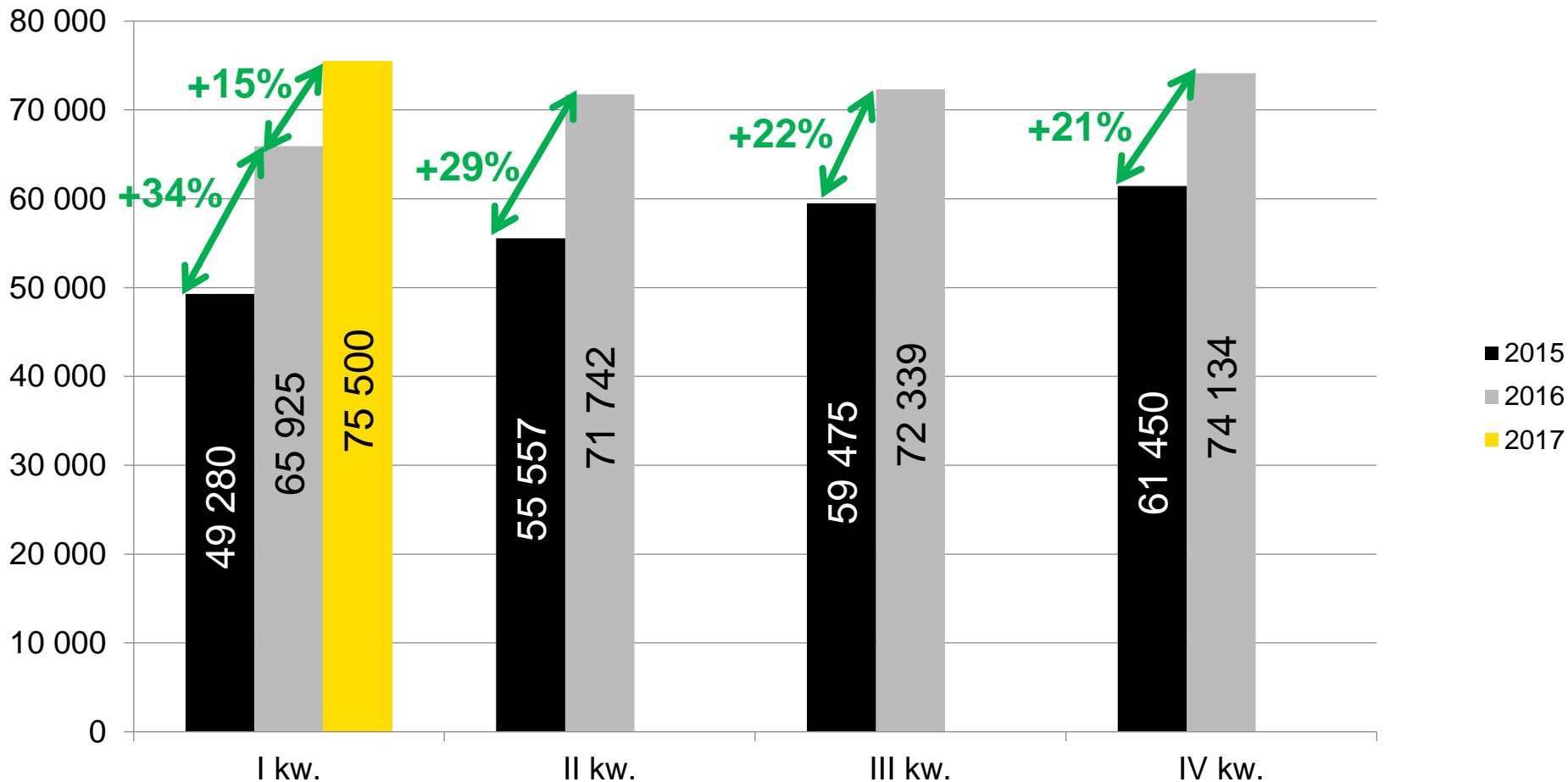

Liczba indeksów na magazynie [*in stock*]





Sprzedaż liczby SKU

Liczba SKU
sprzedanych
w kwartale

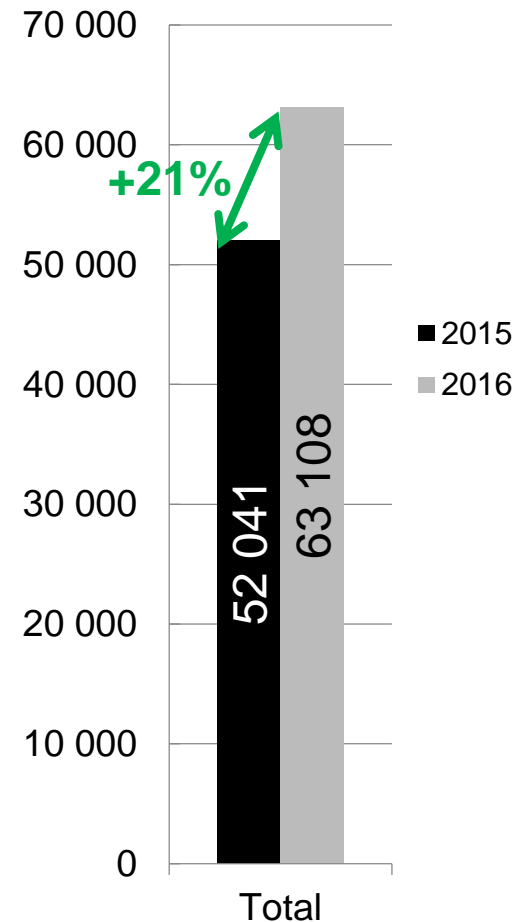
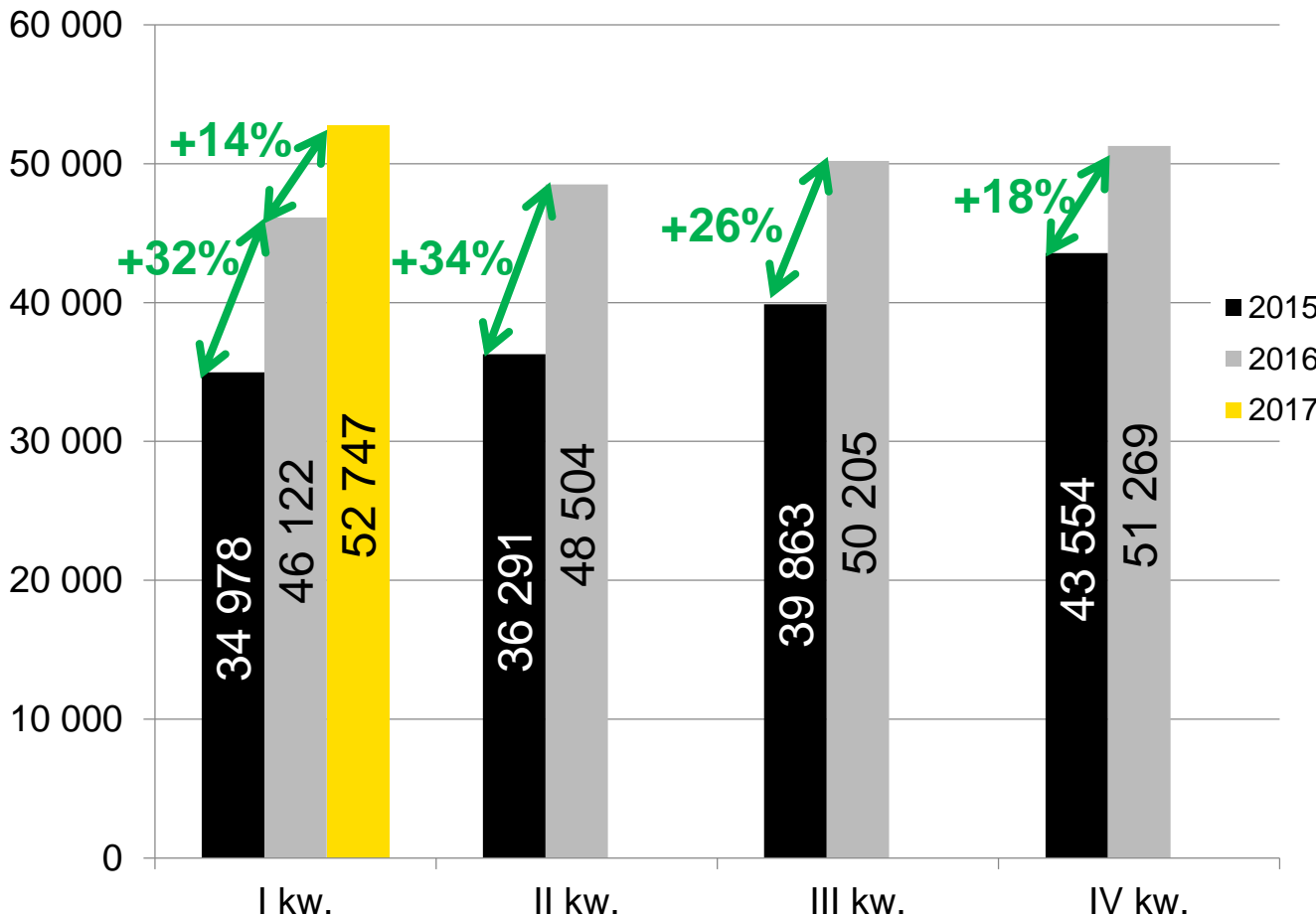

Dotyczy towarów stale utrzymywanych na magazynie





Sprzedaż przez sklep TIM.pl na dzień roboczy

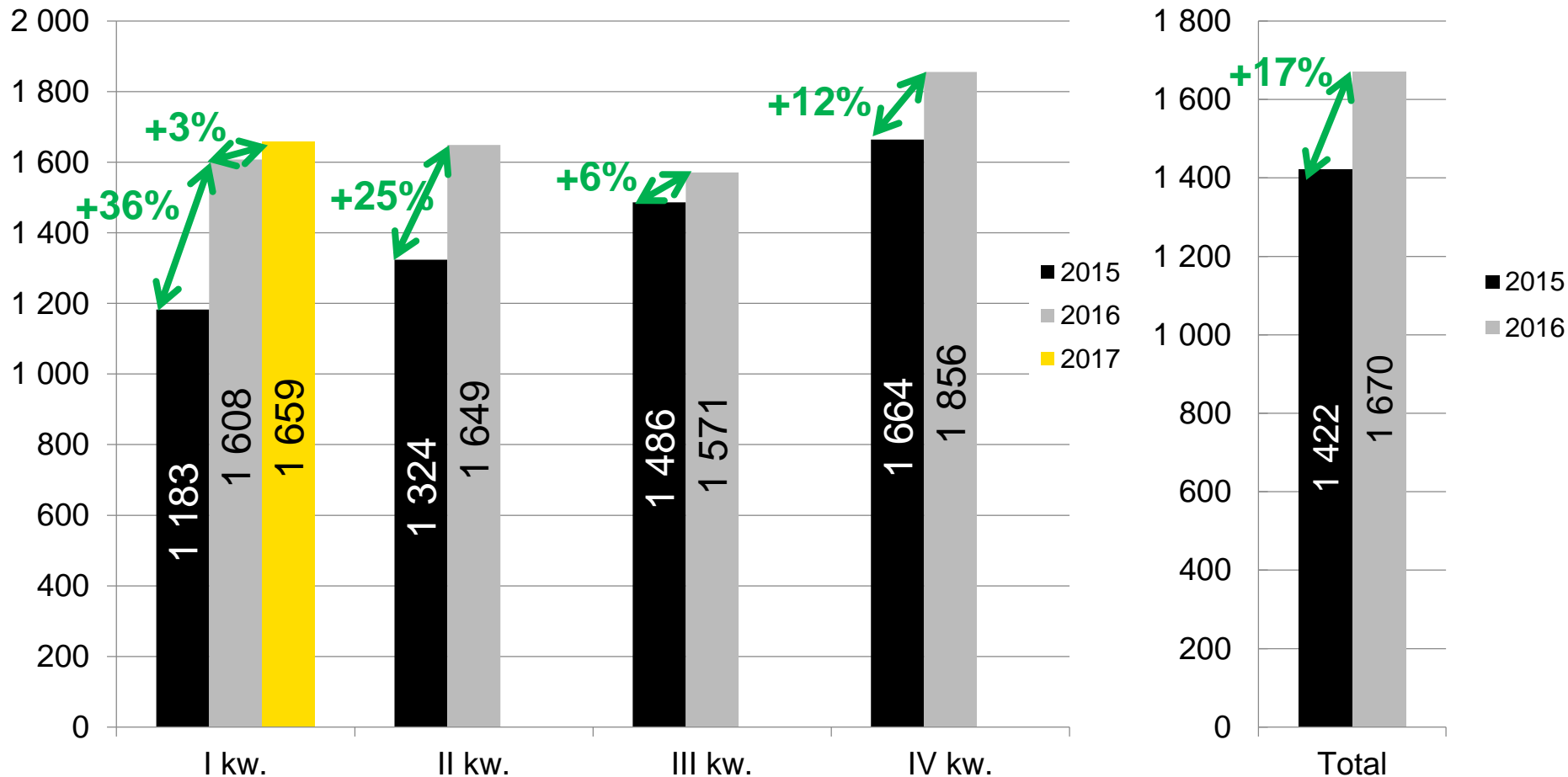

wartości w tys. PLN





Średnia wartość linii w sklepie TIM.pl

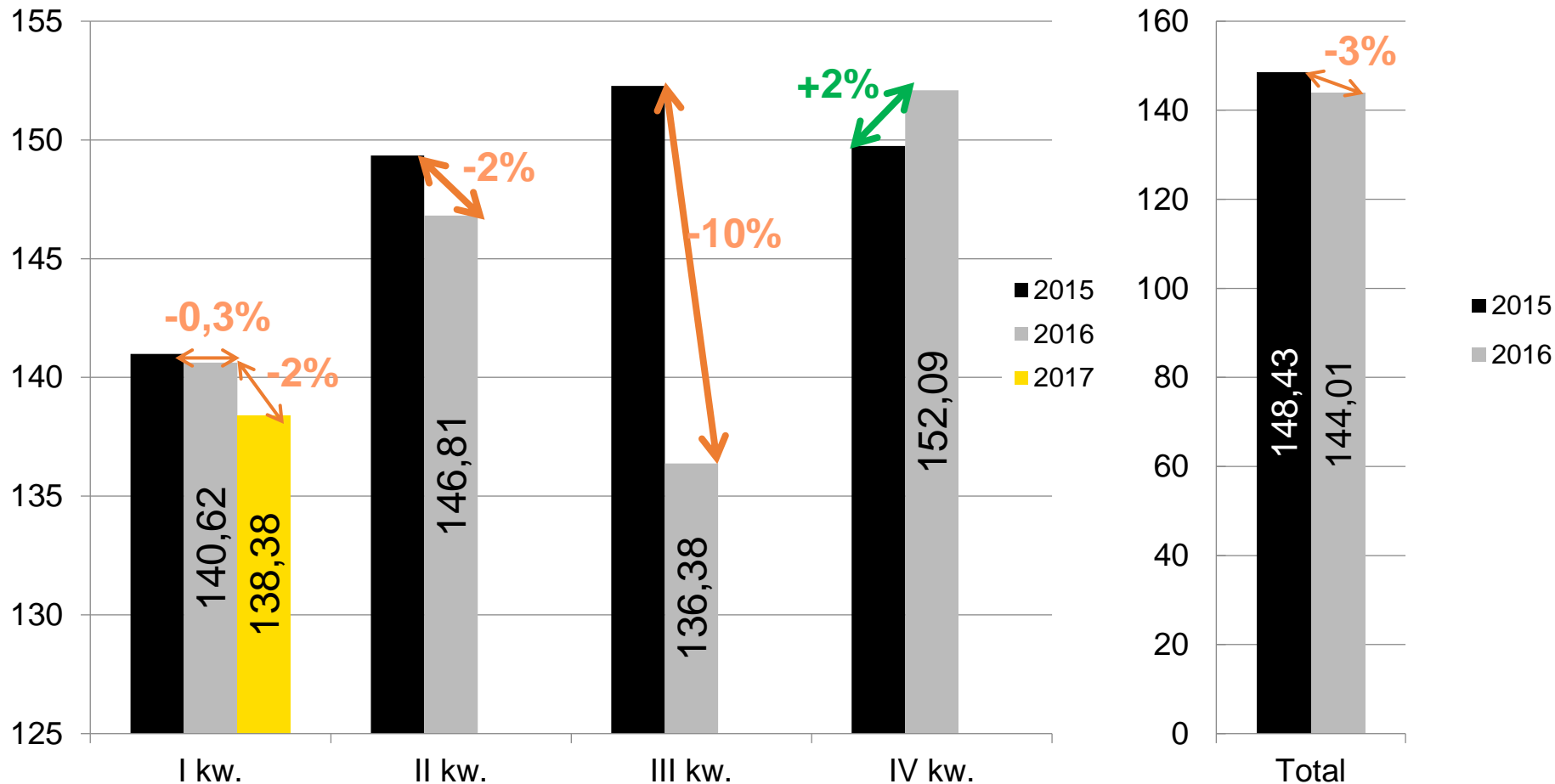

wartości w PLN





Liczba linii w sklepie TIM.pl

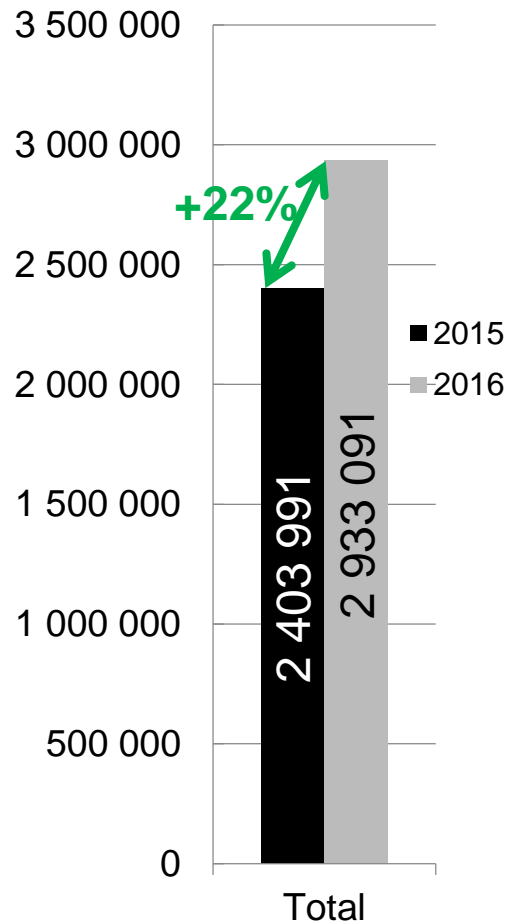
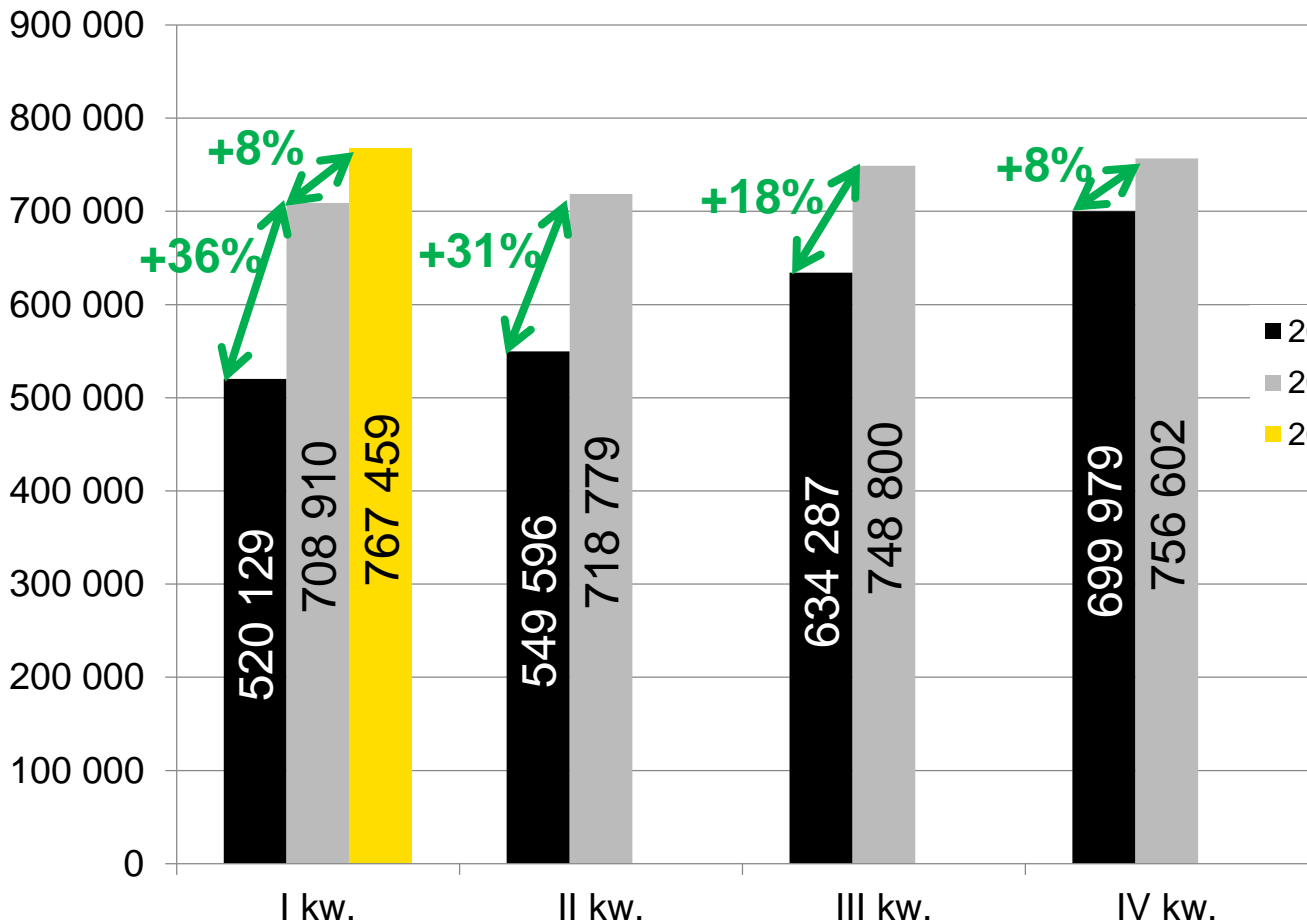



Wzrost efektywności pracowników

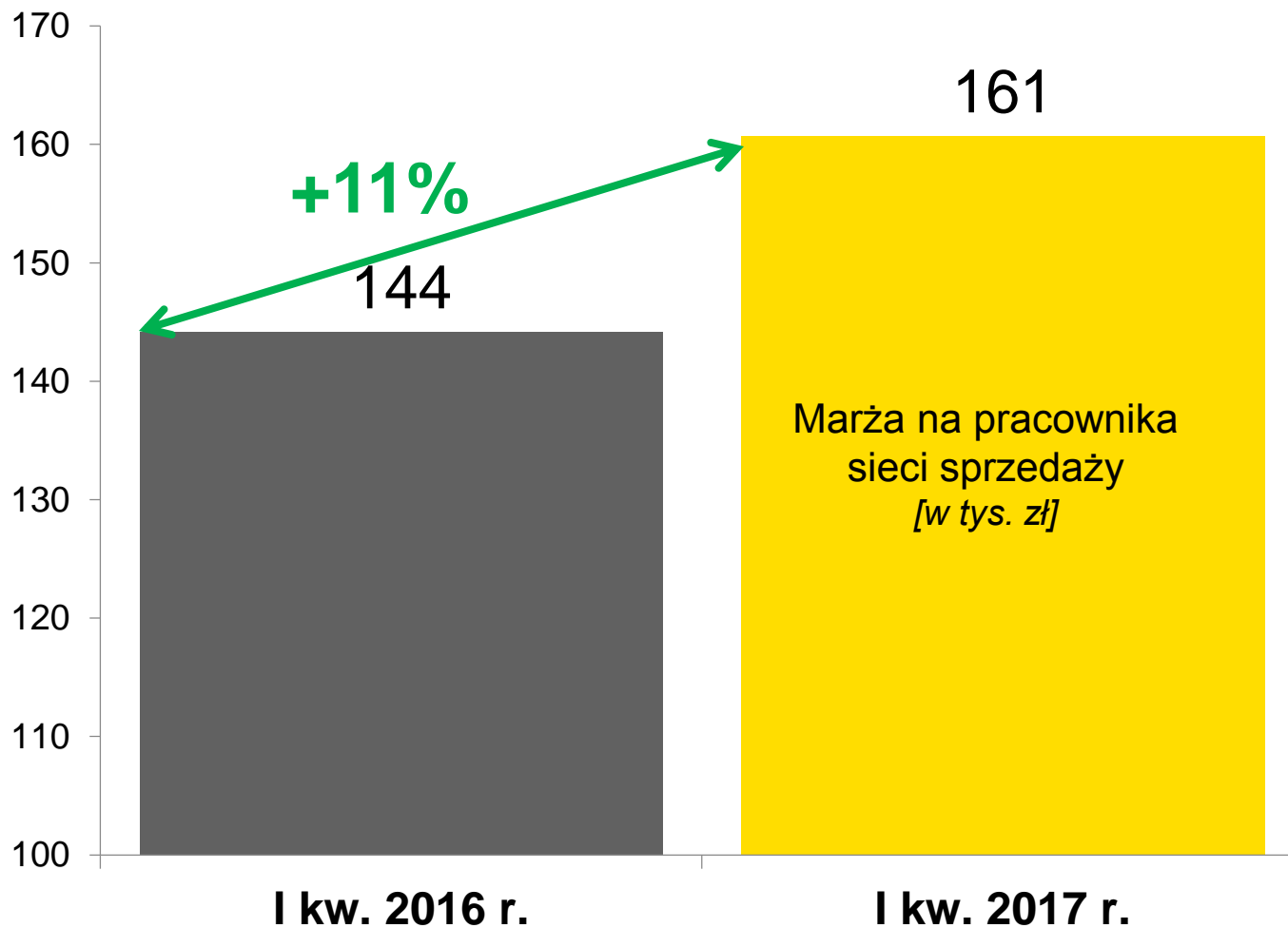



Udział należności przeterminowanych > 30 dni

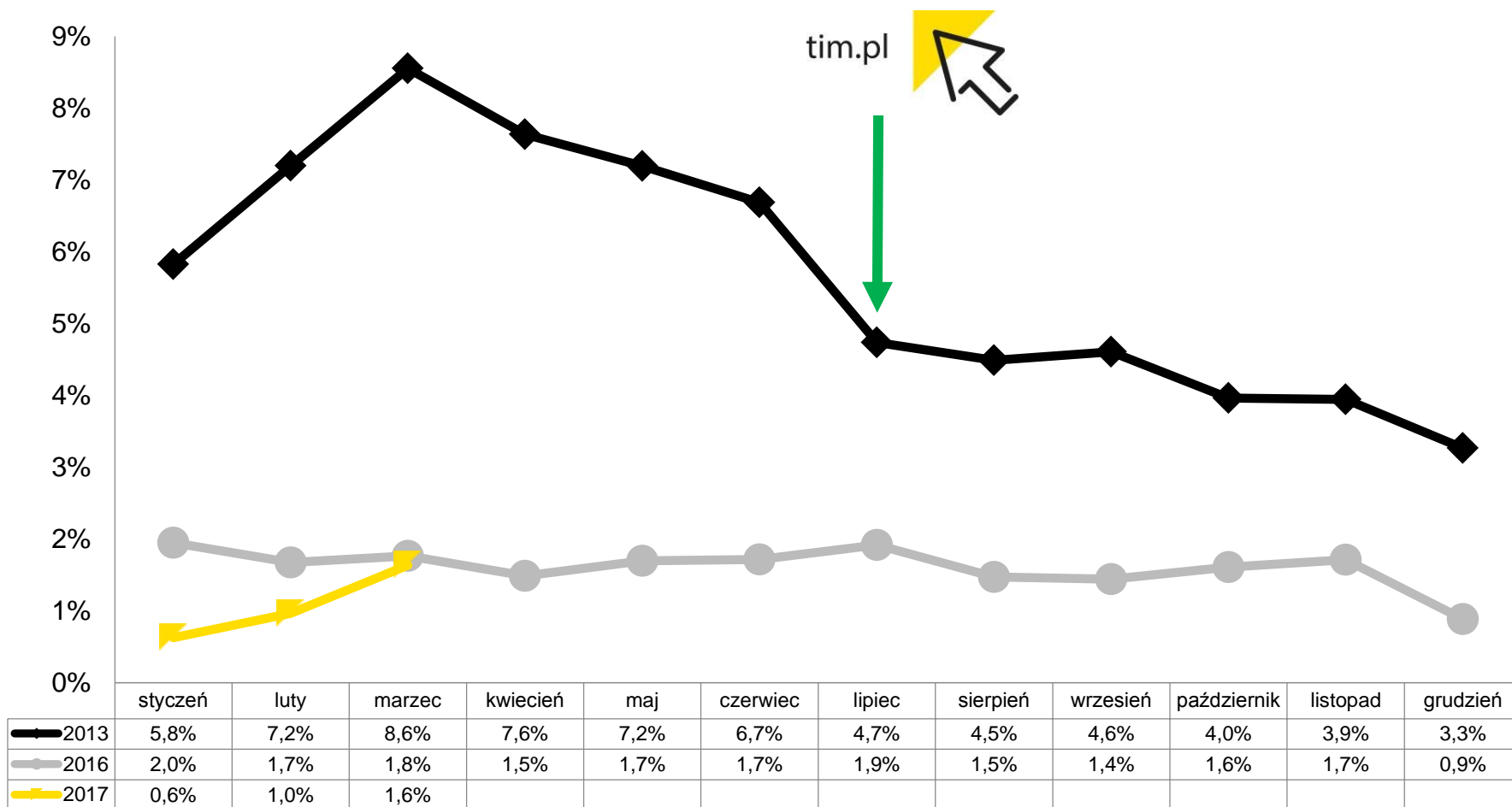



Wyniki TIM SA po I kw. 2017 r. vs I kw. 2016 r. i I kw. 2015 r.

sektor budownictwa I kw. 2017/I kw. 2016: **+3,9%**

	I kw. 2017	I kw. 2016	I kw. 2015	zmiana proc. I kw. 2017/ I kw. 2016	zmiana I kw. 2017/ I kw. 2016	zmiana proc. I kw. 2016/ I kw. 2015	zmiana I kw. 2016/ I kw. 2015
PRZYCHODY	147 646	135 614	114 714	8,9%	12 032	18,2%	20 900
WYNIK NA SPRZEDAŻY	226	- 429	- 557	-	655	-	128
WYNIK OPERACYJNY	463	5 024	- 151	-90,8%	- 4 561	-	5 175
Amortyzacja	877	1 613	1 666	-45,6%	- 736	-3,2%	- 53
EBITDA	1 340	6 637	1 515	-79,8%	- 5 297	338,1%	5 122
Straty, przeceny, likwidacja towaru	909	332	- 166	173,8%	577	-	498









Wyniki GK TIM po I kw. 2017 r. vs I kw. 2016 r. i I kw. 2015 r.

	I kw. 2017	I kw. 2016	I kw. 2015	zmiana proc. I kw. 2017/ I kw. 2016	zmiana I kw. 2017/ I kw. 2016	zmiana proc. I kw. 2016/ I kw. 2015	zmiana I kw. 2016/ I kw. 2015
PRZYCHODY	163 161	147 737	123 621	10,4%	15 424	19,5%	24 116
WYNIK NA SPRZEDAŻY	-1 766	- 387	- 279	-	- 1 379	-	- 108
WYNIK OPERACYJNY	-1 624	4 955	- 88	-	- 6 579	-	5 043
Amortyzacja	2 540	1 689	1 735	50,4%	851	-2,7%	- 46
EBITDA	916	6 644	1 647	-86,2%	- 5 728	303,4%	4 997





TIM, Polska i świat

	USA 	EUROPA 	POLSKA  	
Przychody 2016	136 mld \$	3,64 mld €	546 mln zł	666 mln zł
EBIT	4,2 mld \$	207 mln €	26,2 mln zł	3,6 mln zł
C/Z	150	74	42	199
C/WK	20,5	6,4	5,3	1,8
Kapitalizacja (15 V 2017)	457 mld \$	9,7 mld €	668,6 mln zł	240,4 mln zł
Kapitalizacja/Przychody	3,4	2,7	1,2	0,4



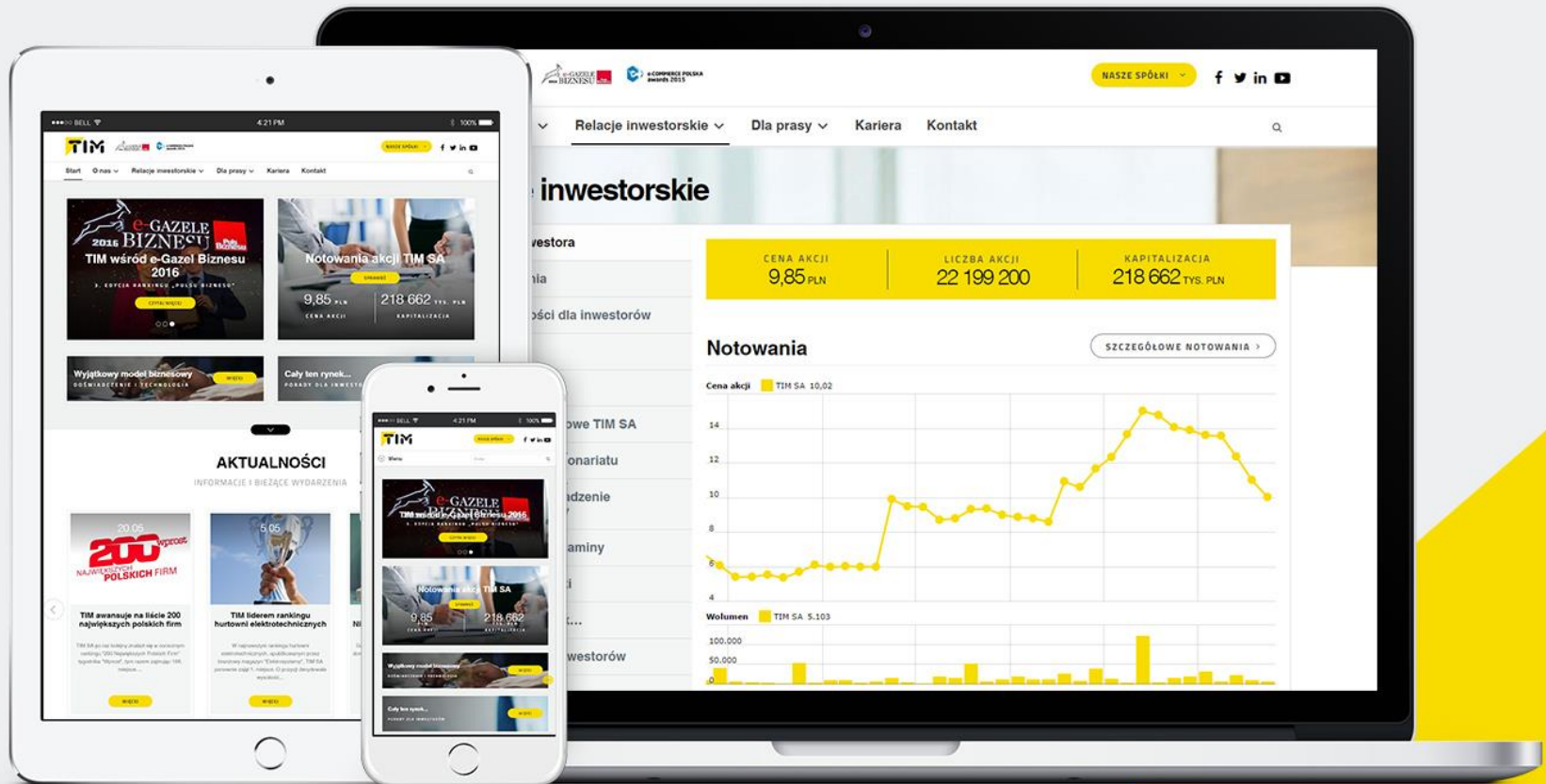

www.timsa.pl

NOWA
ODSŁONA

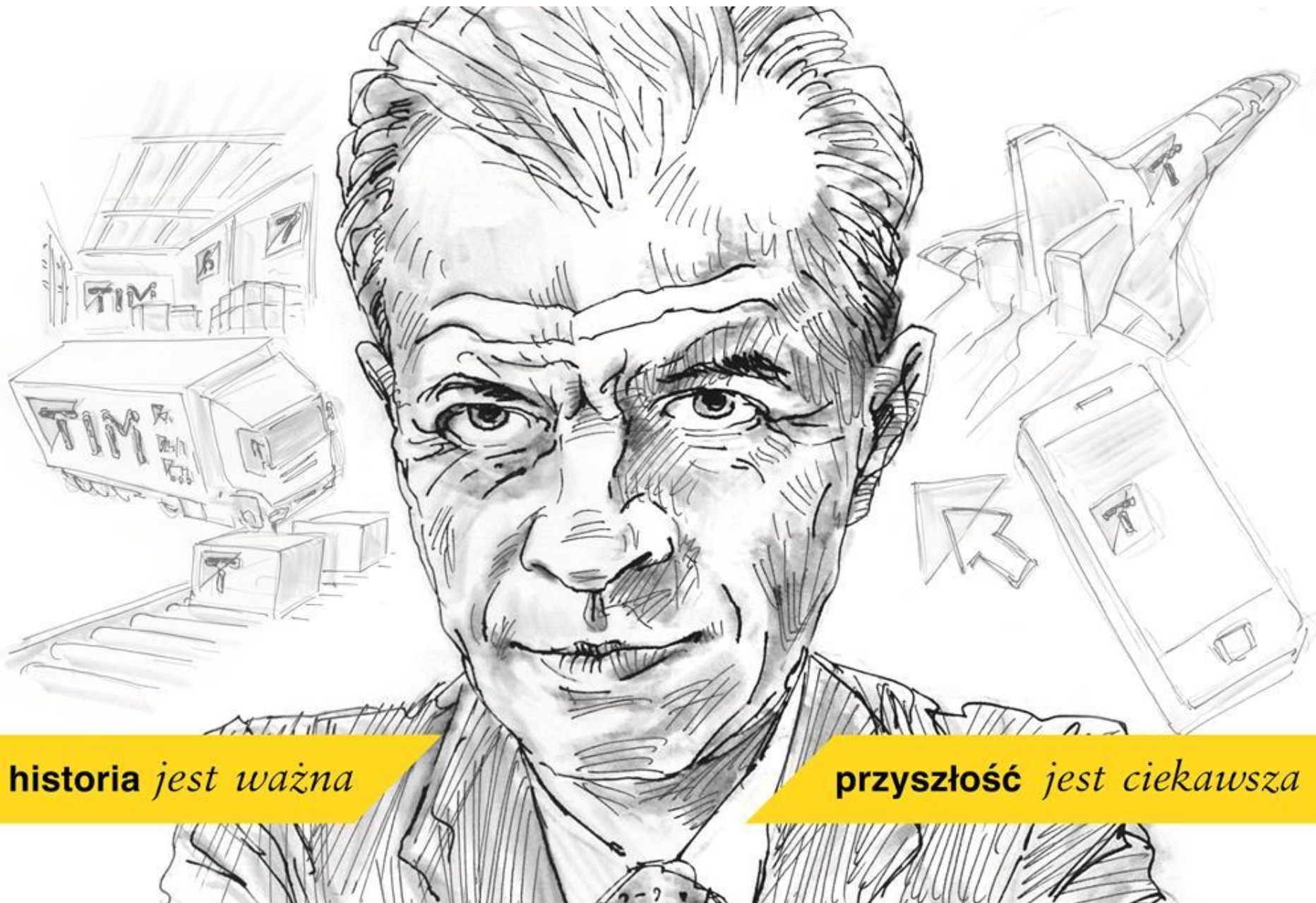

historia *jest ważna*

przyszłość *jest ciekawsza*

Dziękuję za uwagę!